

WIRE TRACER LKZ-700



Wire tracer LKZ-700 is intended to locate electrical cables embedded in different materials (concrete, bricks, wood) in buildings. It can be also used to detect cables located underground. The cables can be detected regardless whether they are live or not and transmitter operation mode can be automatically selected.

Standard accessories of the meter LKZ-700:

- test lead with banana plug; 1,2m; black
- test lead with banana plug; 1,2m; yellow
- pin probe with banana connector - yellow
- pin probe with banana connector - black
- test lead on a reel with banana plugs; 20m red
- Ni-MH battery package 9,6V 2Ah

WAPRZ1X2BLBB
WAPRZ1X2YEBB
WASONYE0GB1
WASONBLOGB1
WAPRZ020REBS
WAAKU04

- „crocodile” clip K01; black
- „crocodile” clip K02; yellow
- carrying case M4
- earth contact test probe (rod); (26cm)
- power supply adaptor Z1, pin 3,5mm
- operating manual
- battery (LKO)

WAKROBL20K01
WAKROYE20K02
WAFUTM4
WASONG26
WAZAS3X5Z1

Optional accessories of the meter LKZ-700:

- test wire reel

WAP0ZSZP1

- earth contact test probe (rod); (80cm)

WASONG80

Sone! S.A.
ul. Wokulskiego 11
58-100 Świdnica, PL
tel. +48 74 85 83 860
fax +48 74 85 83 809

export@sonel.pl
www.sonel.pl



LKZ-700

- **Detection of wires and cables (live or not):**

- detection of cables in ceilings, walls and floors,
- detection of breaks in cables,
- tracing cables in building installation,
- locating power points and switches in buildings,
- locating short circuits between leads,
- tracing shielded cables,
- tracing cables in metal ducts.

- **Identification of fuses on the distribution board.**

- **Tracing underground cables.**

- **Tracing conductive water and heating pipelines.**

- **Non-contact detection of live cables.**

- **Features:**

- signaling of transmitter and receiver operation by LED and sound,
- operation in wide range of rated voltage, up to 500V RMS,
- three modes of transmitter amplification,
- automatic or manual selection of transmitter operation modes,
- adjustment of receiver sensitivity level (ZOOM function),
- four modes of wire tracer operation - voltage, current, current-voltage and "power",
- transmitter's battery charging - high efficiency and low costs.

Electric security:

- type of insulation double, according to EN 61010-1
- measurement category CAT III 600V acc. to EN 61010-1
- transmitter's protection class acc. to EN 60529 IP40
- receiver's protection class acc. to EN 60529 IP40

Other technical data:

- transmitter's power supply battery pack SONELE/Ni-MH 9,6V 2Ah
- transmitter's max working voltage 500Vrms (707Vamp)
- transmitter's dimensions 230 x 67 x 36 mm
- transmitter's weight approx. 490 g
- battery charging temperature 0...+40°C
- detector's max range („M" mode) 2m
- non-contact neon max range 20cm (in air), 3cm (in concrete)
- receiver's power supply battery 9V 6LR61 alkaline
- receiver's dimensions 210 x 82 x 24 mm
- receiver's weight approx. 200 g

Rated operational conditions:

- operating temperature -20...+50°C

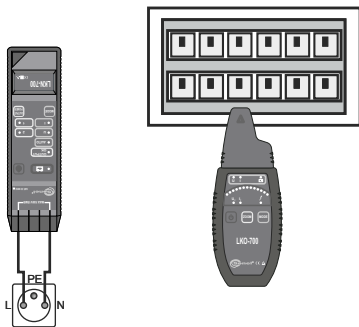

Fig 1. Identification of circuit breakers in a distribution board.

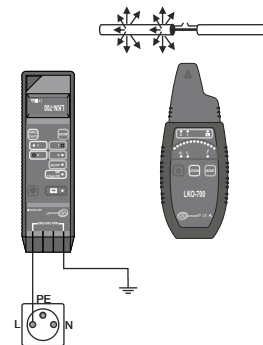

Fig 2. Localization of conductors and breaks in cables.

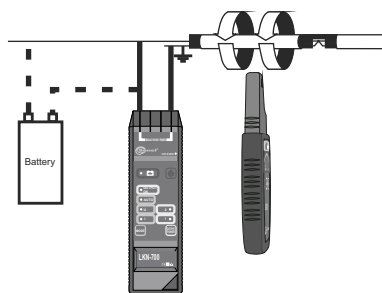

Fig 3. Locating short circuit in a cable.

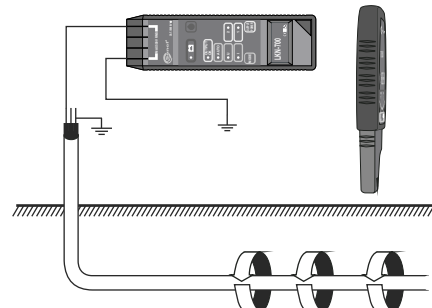

Fig 4. Locating underground cables.